

Applying Configuration Management to Data Centres

David Cuthbertson BSc MBCS MIOD

Mobile 07717 883177

david.cuthbertson@squaremilesystems.com



Overview

- Data Centre Challenges
- Difference between CMS approaches
 - Service Management
 - Data Centre Infrastructure
- Type of CIs and Dependencies
- Implementation issues

Why apply CM to Data Centres?

- Becoming more complex
- Potential disruption is greater
- Best practices are mainly informal
- Lack of investment in process
- Knowledge gaps increasing
- “Green” issues
 - Legislation
 - Cost of energy
- Change is the problem
 - Can ITIL techniques help?

Business Processes

Departmental, Company

Services

End user, infrastructure, supplier

Applications

PC, server, mainframe, SOA

Virtual Infrastructure

PCs, Network, Servers, Storage, DBMS

Hardware Infrastructure

PCs, Network, Servers, UPS, Storage, Other

Fixed Infrastructure

(Cabling, Power, Cabinets, Rooms, Buildings)

Data Centre needs

Different Teams, Different Focus

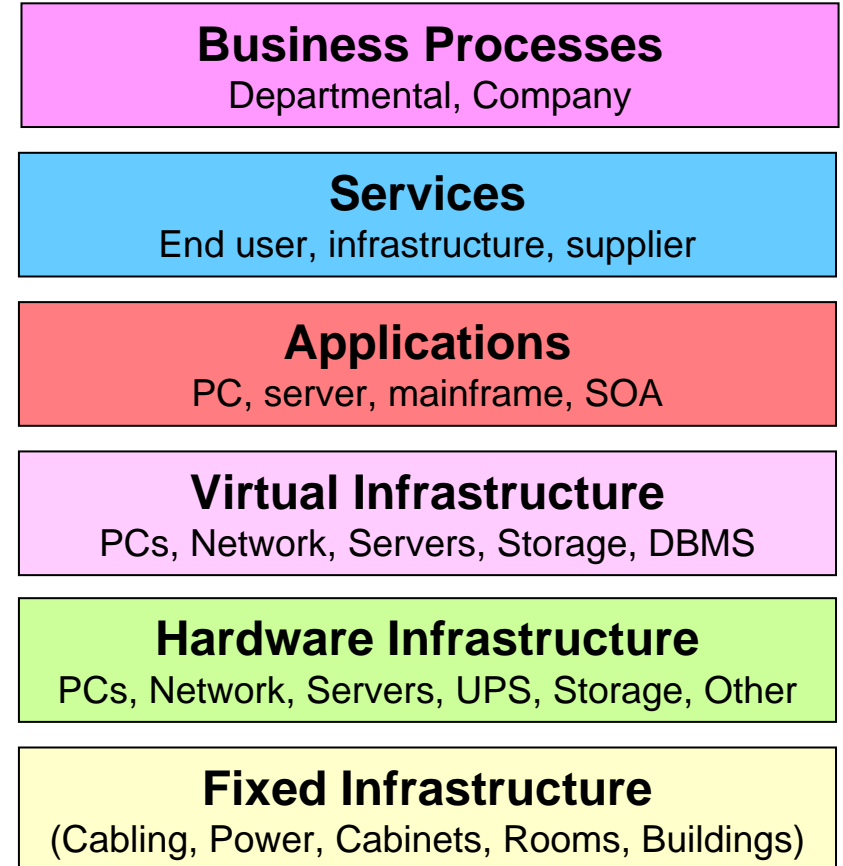
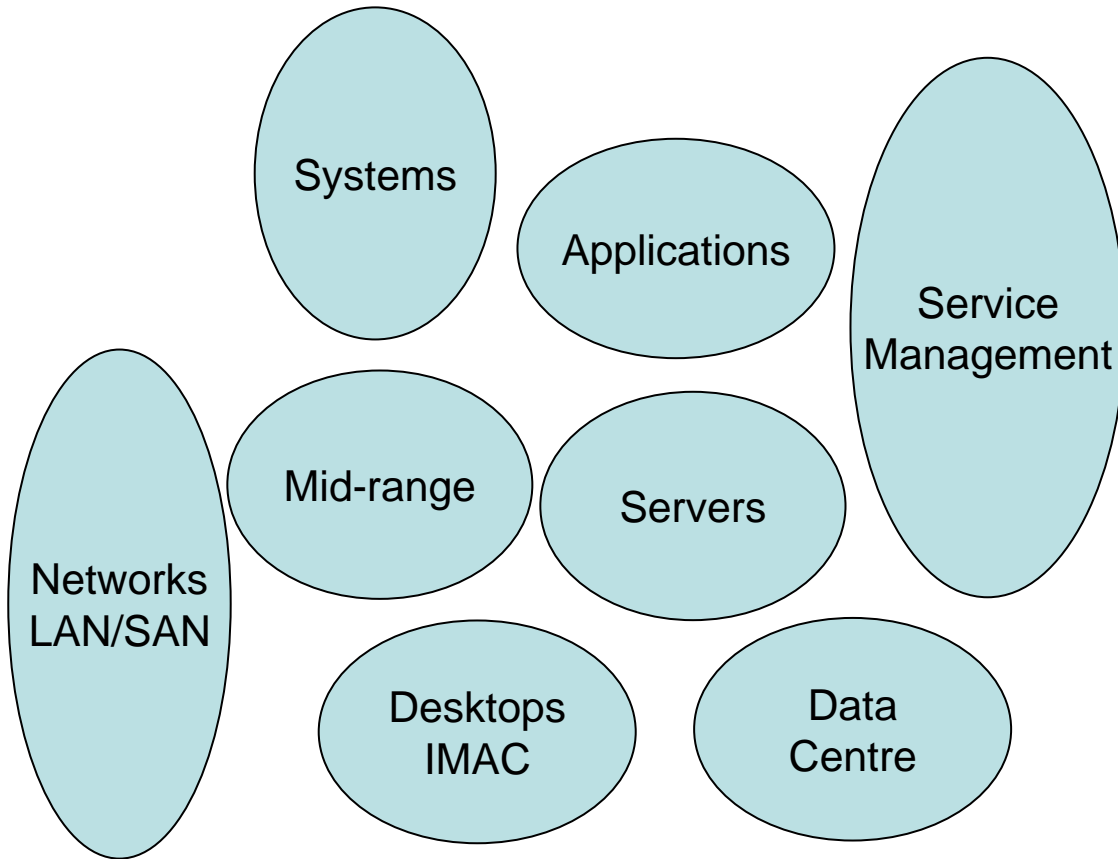

Specific Data Centre Challenges

- Power management
- Cooling
- Connectivity management
- Optimising of space
- Speed of provisioning
- Reacting to short-term projects/emergencies
- Capacity and demand planning
- Predicting change impact
- Lack of integration with Configuration Management initiatives

Typically 30% of data centre power is used for IT Equipment

Changing Requirements

BEFORE

AFTER

No. of Servers per cabinet	3-6	30-40
Power Disipated per cab.	300-2000W	3kW - 25kW
Current service to cabinet	16A	32 A or 3 phase
Types of Equipment	Servers Monitor KVMs Power Strips UPS	Blade Servers Power Distribution Units MidSpan Boxes Disk Arrays (Storage) Smart Power Strips Regular Power Strips
Network types	100Base-T	1G, 10G, SAN
No. of Cables	1 or 2	2 to 6
Power	1 or 2	5 to 10
(per device)	20-30	300 - 400
Network		
Total		

New Technology Challenges

Sun Blade 8000 Blade Chassis

- 4 Power supplies (N+1) 9kW
- 3 chassis per rack



HP C7000 Blade Chassis

- Up to 6 Power Supplies 13kW
- 4 chassis per rack



Cisco Nexus Data Centre Switch

- 3 Power Supplies 12kW
- 384 network ports



Server, LAN, SAN and Management cards!

The ITIL Version 3 CMS

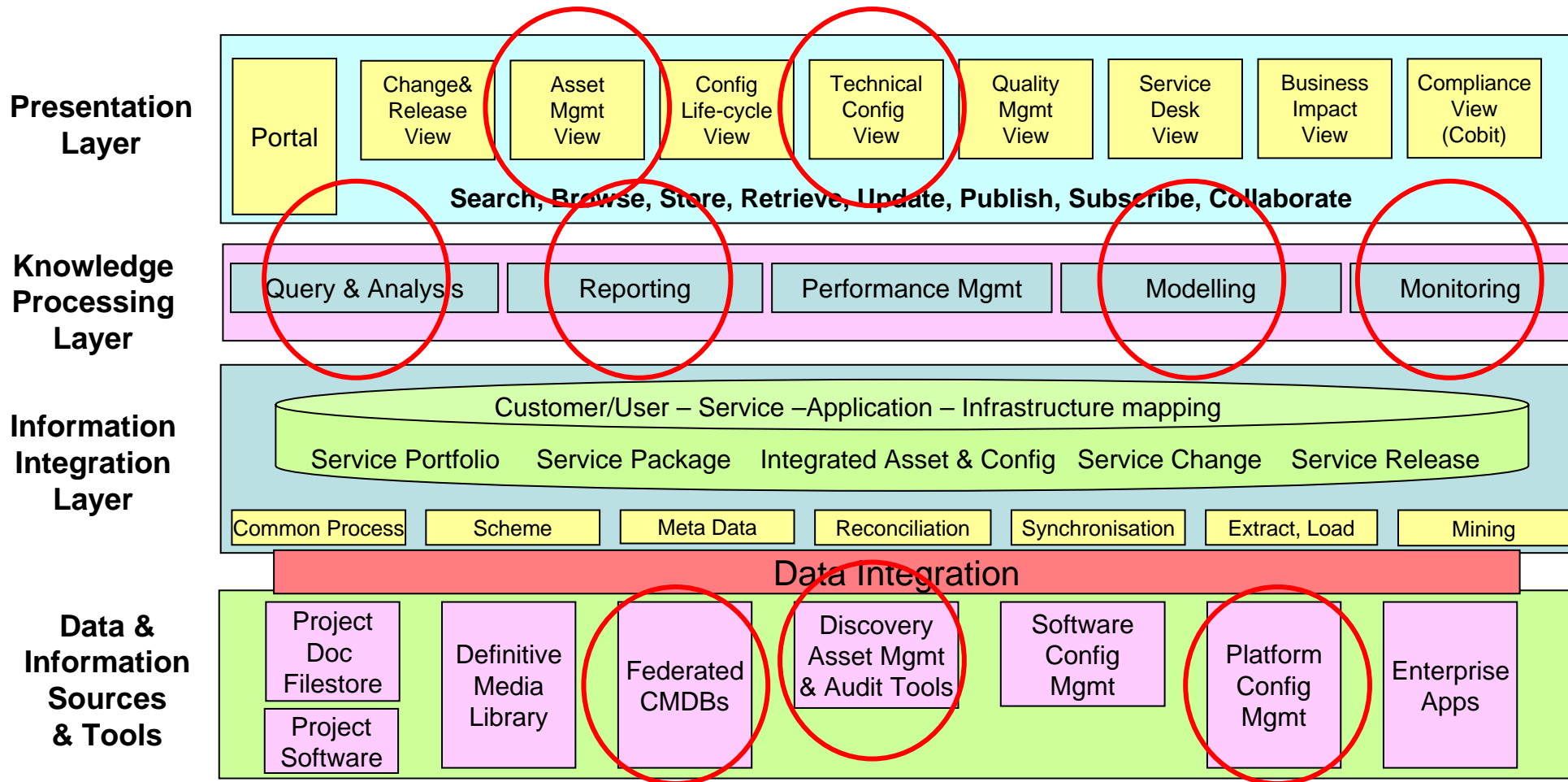

What functions does your ITIL CMS fulfil?

- Asset Management
 - Life cycle of a component, often with financial value
- Application Development and Releases
 - Life cycle of applications, systems and versioning
- Service management
 - Service relationships between CIs, including change, incident, problems (Service Maps)

Data Centre

- Technical architecture
 - Technical relationships between CIs, network diagrams, SAN links
- Physical architecture
 - Rooms, cabinets, chassis, power, cabling, space

Typical CMDB/CMS Update Issues

Change Issue	Asset View	Release View	Service View	Technical View	Data Centre
Install a new cabinet, with power and cabling					Y
Add a full blade server chassis to a cabinet	Y				Y
Connect a blade to the network, SAN and update management tools				Y	Y
Move an existing server to the blade keeping the same name	Y	?		Y	Y
Virtualise the server onto a blade	?	Y	Y	Y	
Create a new virtual test server	Y	Y		Y	
Release an updated version of a bespoke application		Y			

What type of CMS does a Data Centre need?

- Device Inventory
 - Anything that takes up space, power or is connected through cabling
 - Includes daughter cards, blades, KVMs, power strips, patch panels etc.
- Space
 - Amount of space taken up by components
 - Position and orientation within computer room
- Connectivity
 - Power
 - Network
 - SAN
 - Other
- Coordination with other data sources
 - Service, ownership, monitoring etc.



Why is Position and Orientation Important?

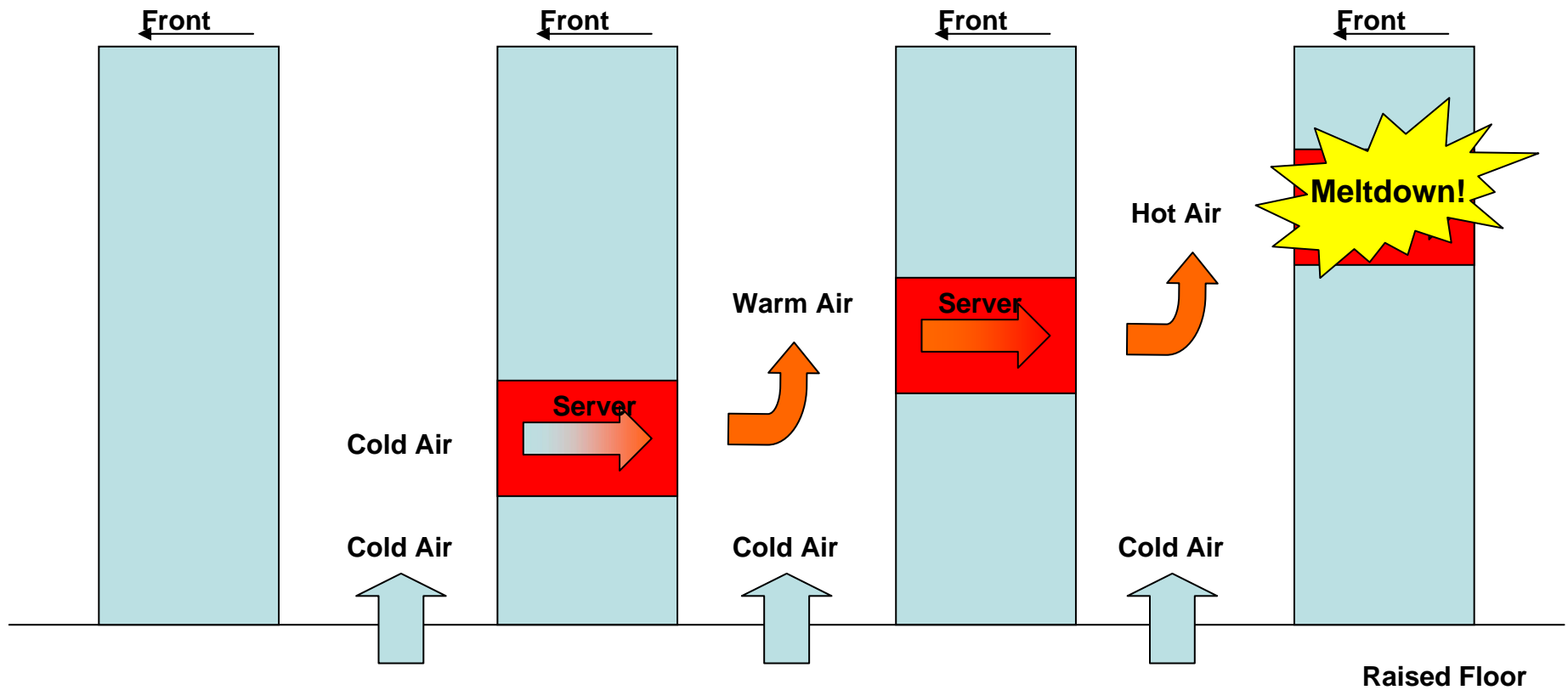

Hot & Cold Aisles

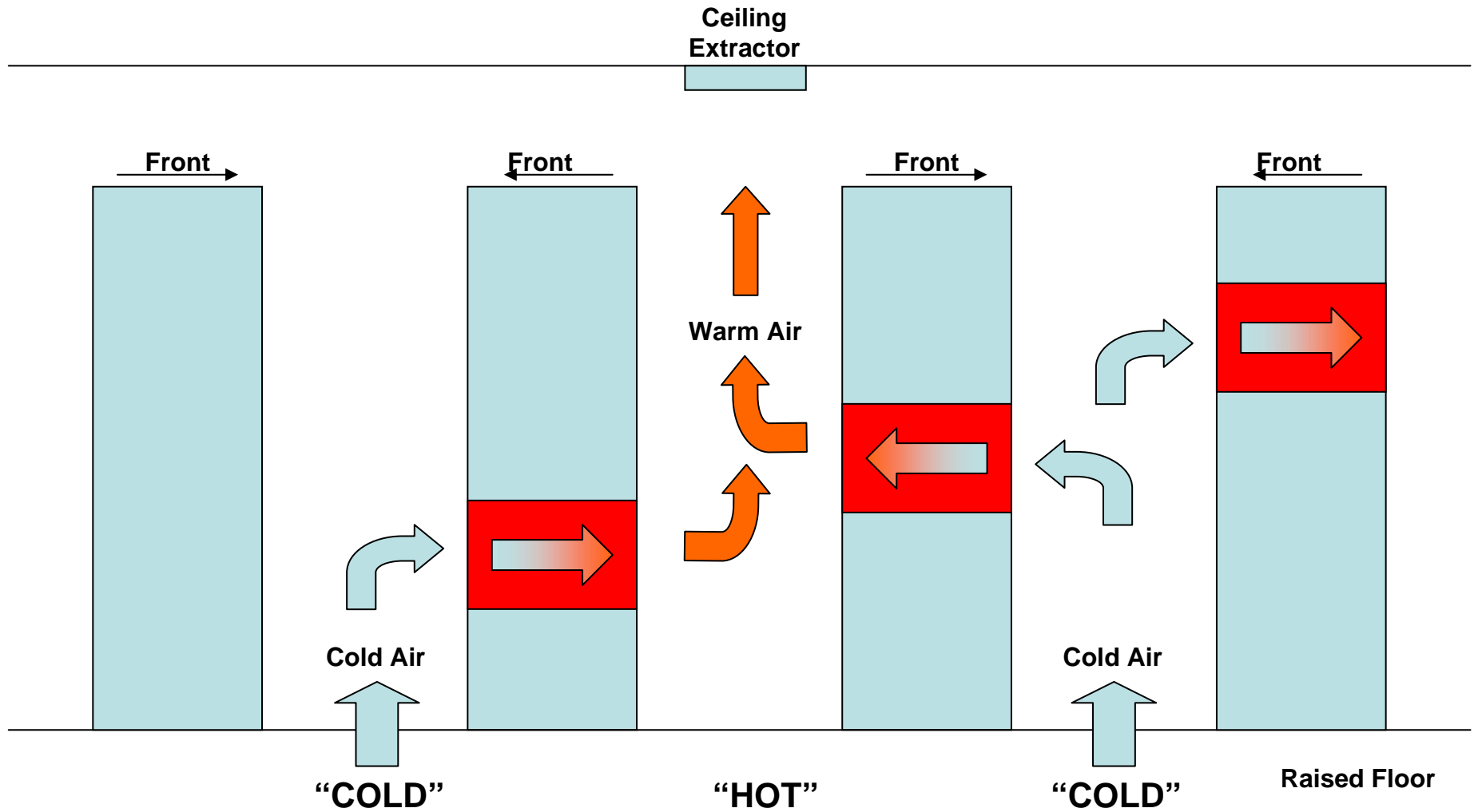

In Practice – its more difficult

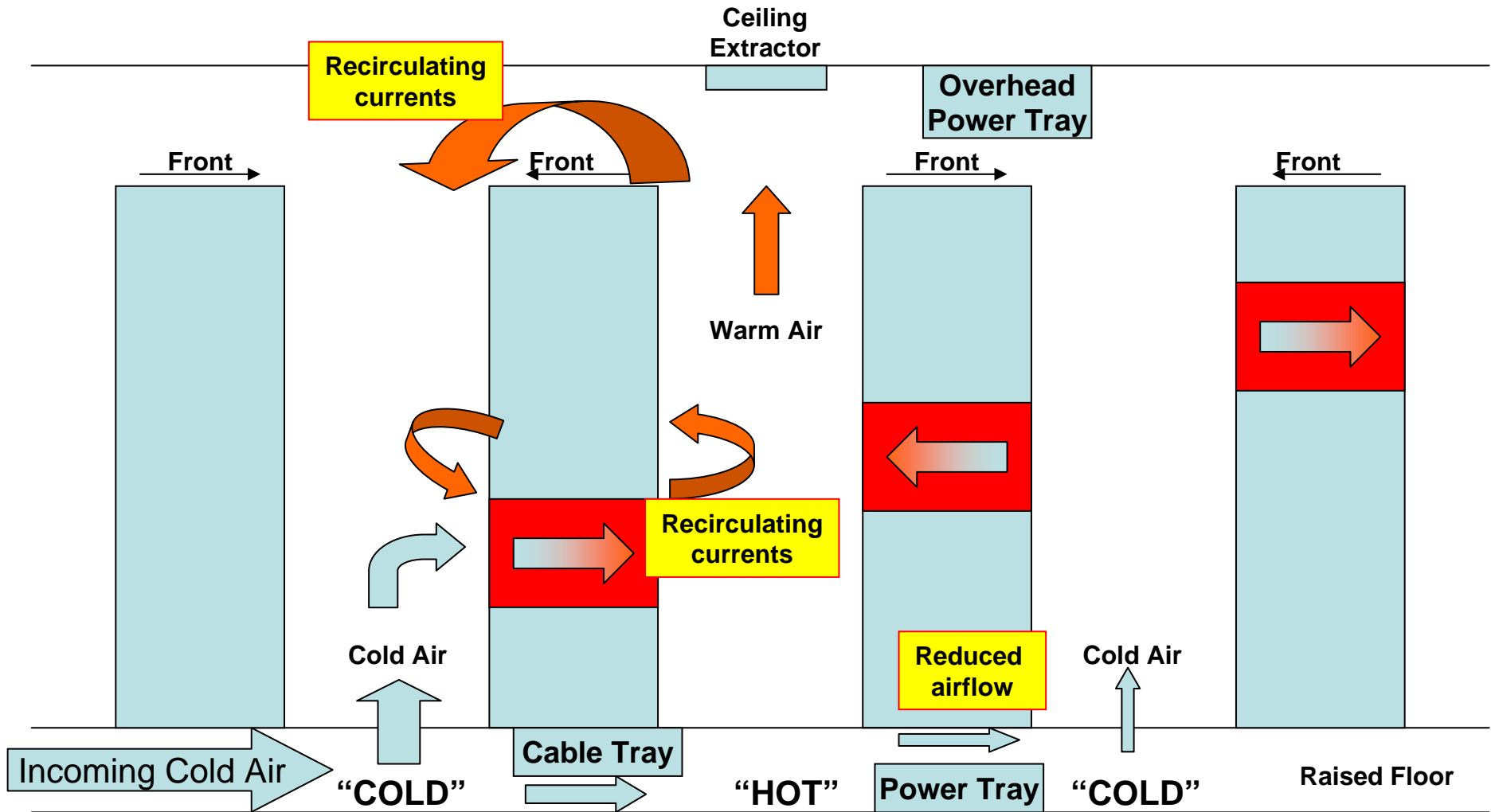

Power View

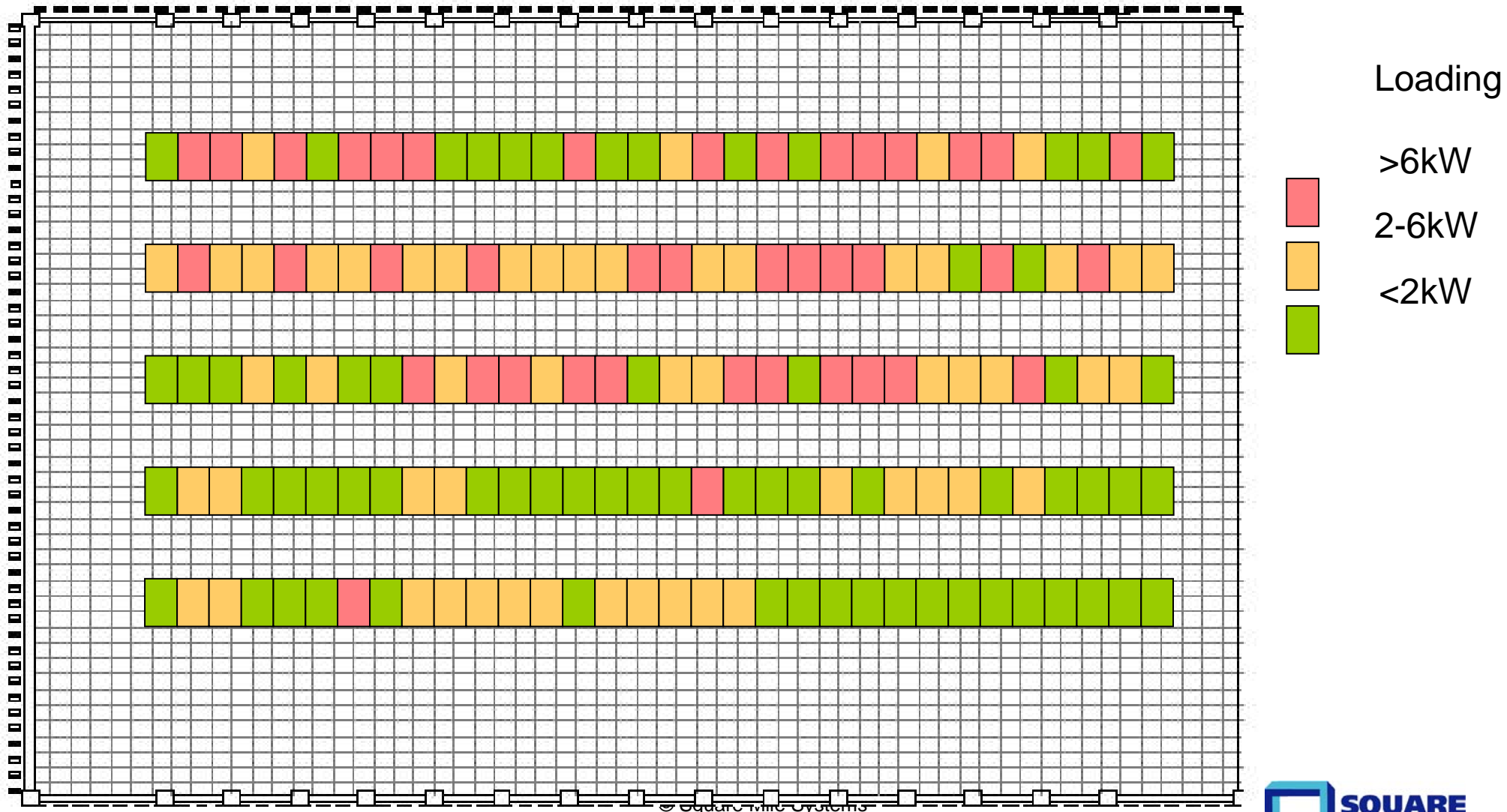

What % loading do we use?

- Equipment power (max, derated, actual)
- Circuit breaker rating
- Current breaker loading + failover reserve

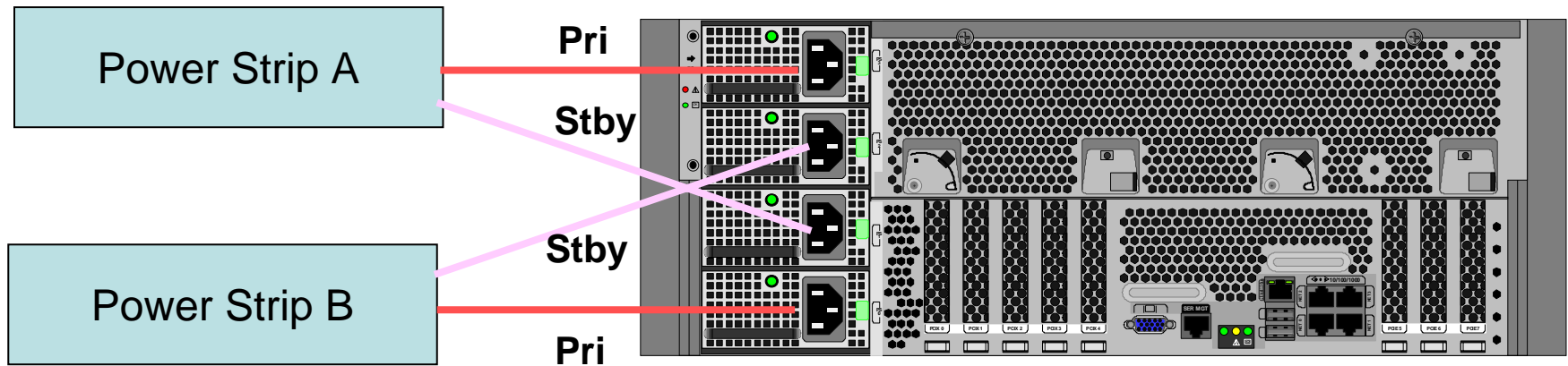

Practical Issues

- Who owns the problem of creating and maintaining an end to end data centre knowledge base?
 - Facilities?
 - IT Data Centre teams?
 - Platform teams?
 - Service management?
 - Development teams?
- Where do you start?
 - Toolsets
 - Process
 - People

Isn't this similar to the problems of ITIL configuration management?



Differences in Approach

- ITIL Configuration Management
 - Focus on CIs that need to be controlled for service management processes
 - change, incident, problem, release coordination
 - Dependencies are often few in type and hierarchical in nature
 - Life cycle focused on procurement, transition and change control
 - Typically covers the “live” or active infrastructure
- Data Centre Configuration Management
 - Focused on hardware and physical issues in a location
 - Dependencies are many and varied, with large numbers to document
 - Covers live, non-live, fixed infrastructure, not in use, etc.
 - Granularity is small – ports, cables, cards

Differences in Approach

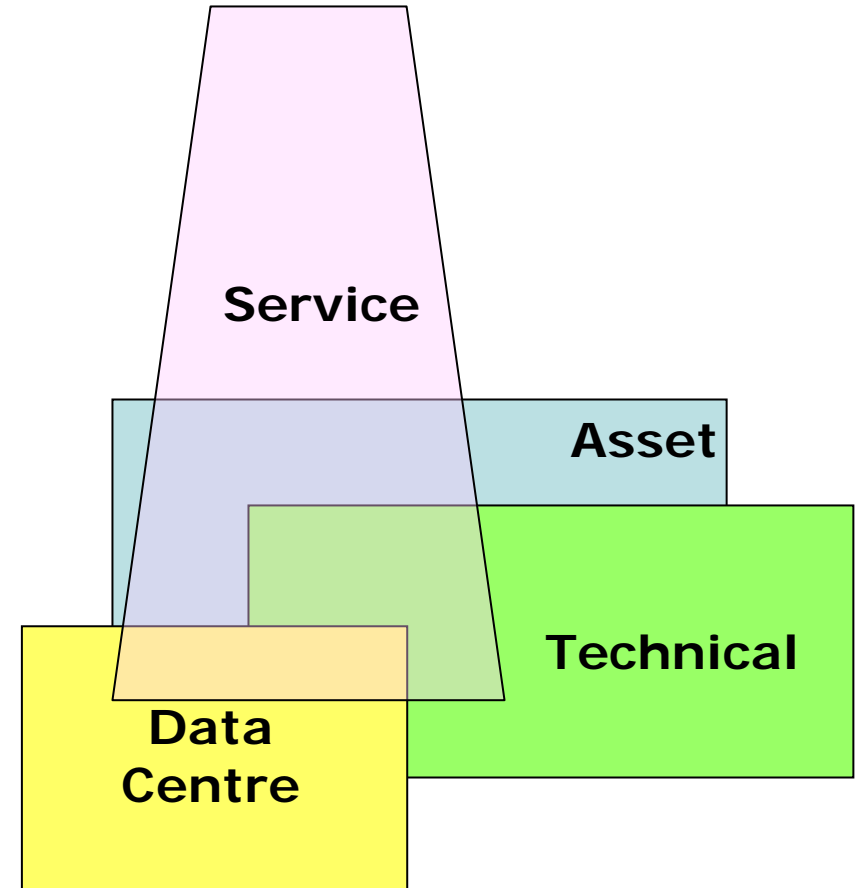
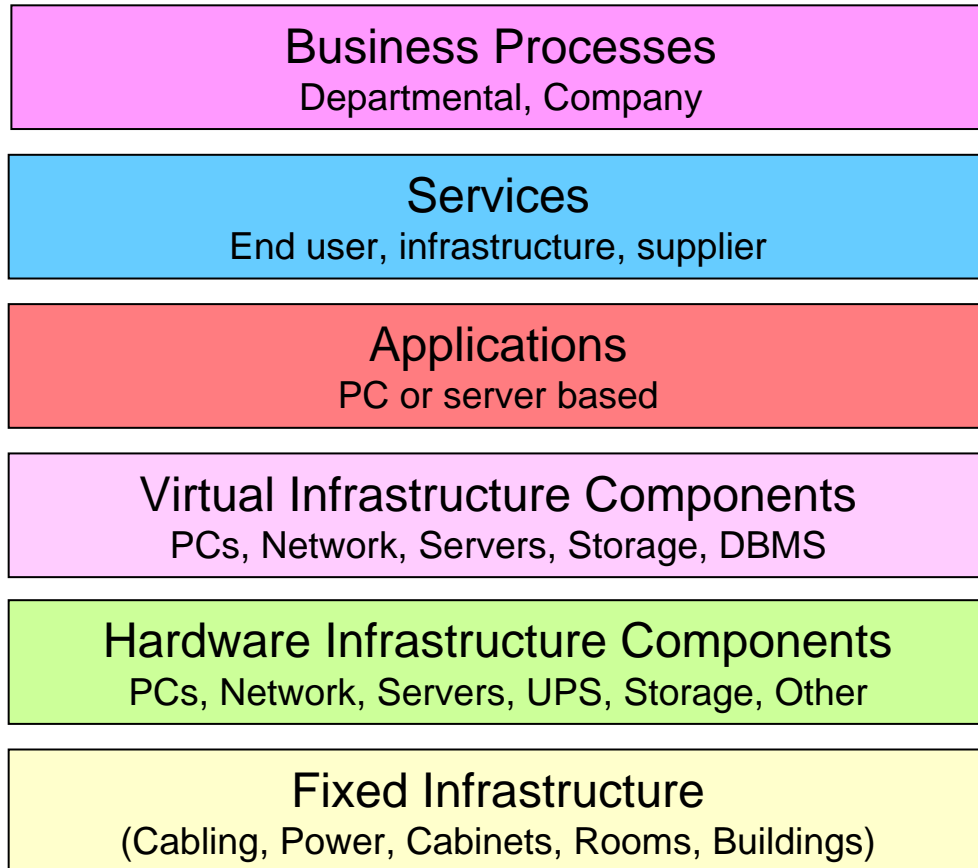

Adopting ITIL CM Principles

- Identification
 - What do you want to control?
 - Determine the level of detail
 - What attributes and relationships do you record?
- Control
 - How and when do you control recording, updates etc.
 - Handover responsibilities
- Status
 - Is a device or port live, installed, operational, reserved, unallocated
- Verification/audit
 - Check the processes are working

Other Common Sense Principles

To manage change:

1. Establish a baseline
2. Manage change using process
3. Verify processes are working

Applying configuration management in the data centre helps to build a controlled, robust computing environment to deliver services from.

What choice is there?

Change Impact...

ITIL Change

- Devices affected
- Services impacted
- Users or processes impacted
- Risk assessment & mitigation
- Change process

Data Centre Change (in addition)

- Power feeds affected
- Devices also in the same cabinet
- Devices connected to those in the cabinet
- Power consumed by devices in the cabinet
- Power consumed by devices in adjoining cabinets
- Resilience supporting affected devices
- Virtual devices running on the physical devices and owners
- Software, systems and services using the devices

Summary of Information Sets

- There is potentially a huge amount of data, so focus is required
- The service desk CMDB is unlikely to meet the specific needs of data centre teams, but still needs to be implemented
- Knowledge of components will always be duplicated, so focus on reducing the number of possible data sets
- Start with information held by specific teams, before looking at information sets across teams